

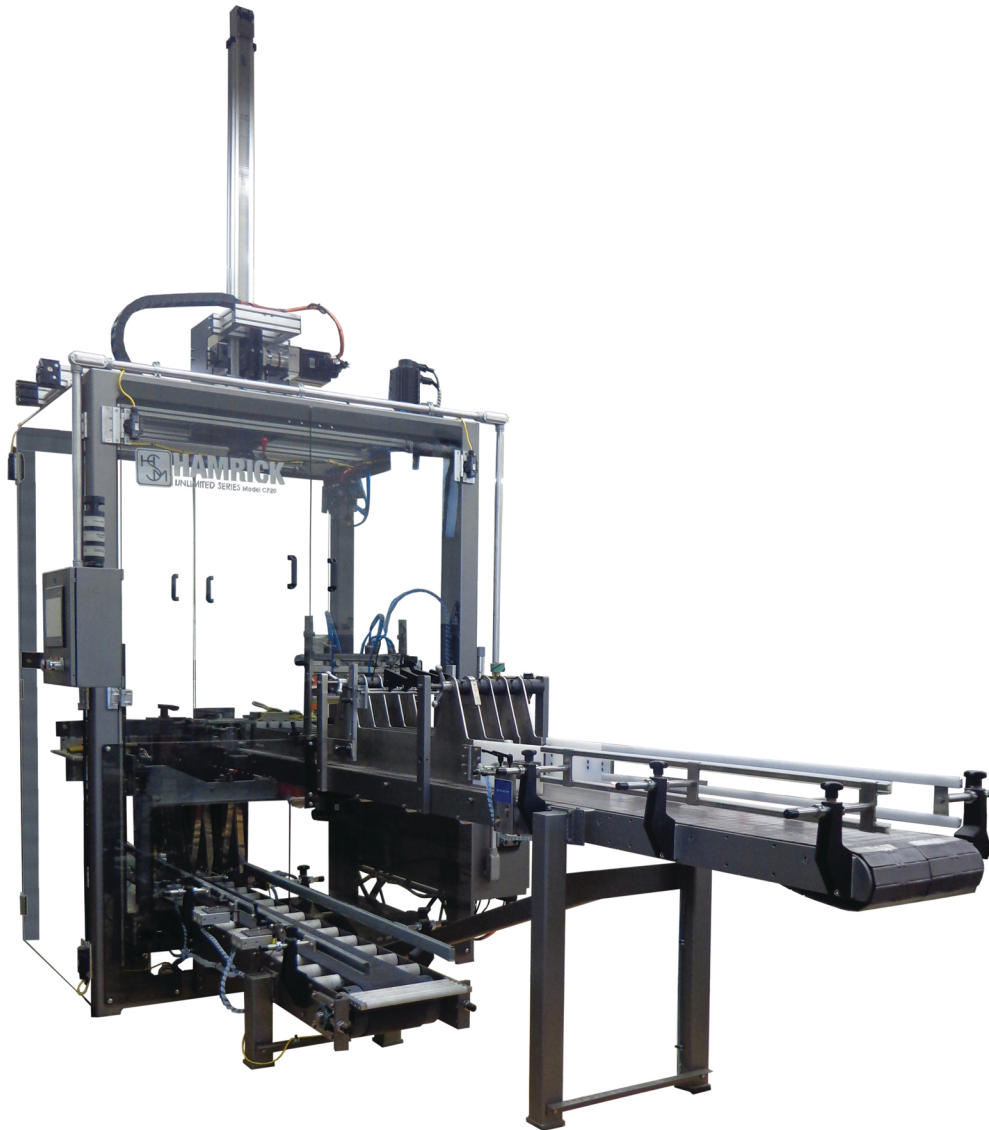

HAMRICK

CP15 PICK & PLACE CASE PACKER



Round
Containers



15
Cases Per Minute



Low to Medium
Production Volume



HAMRICK

CP15 PICK & PLACE CASE PACKER

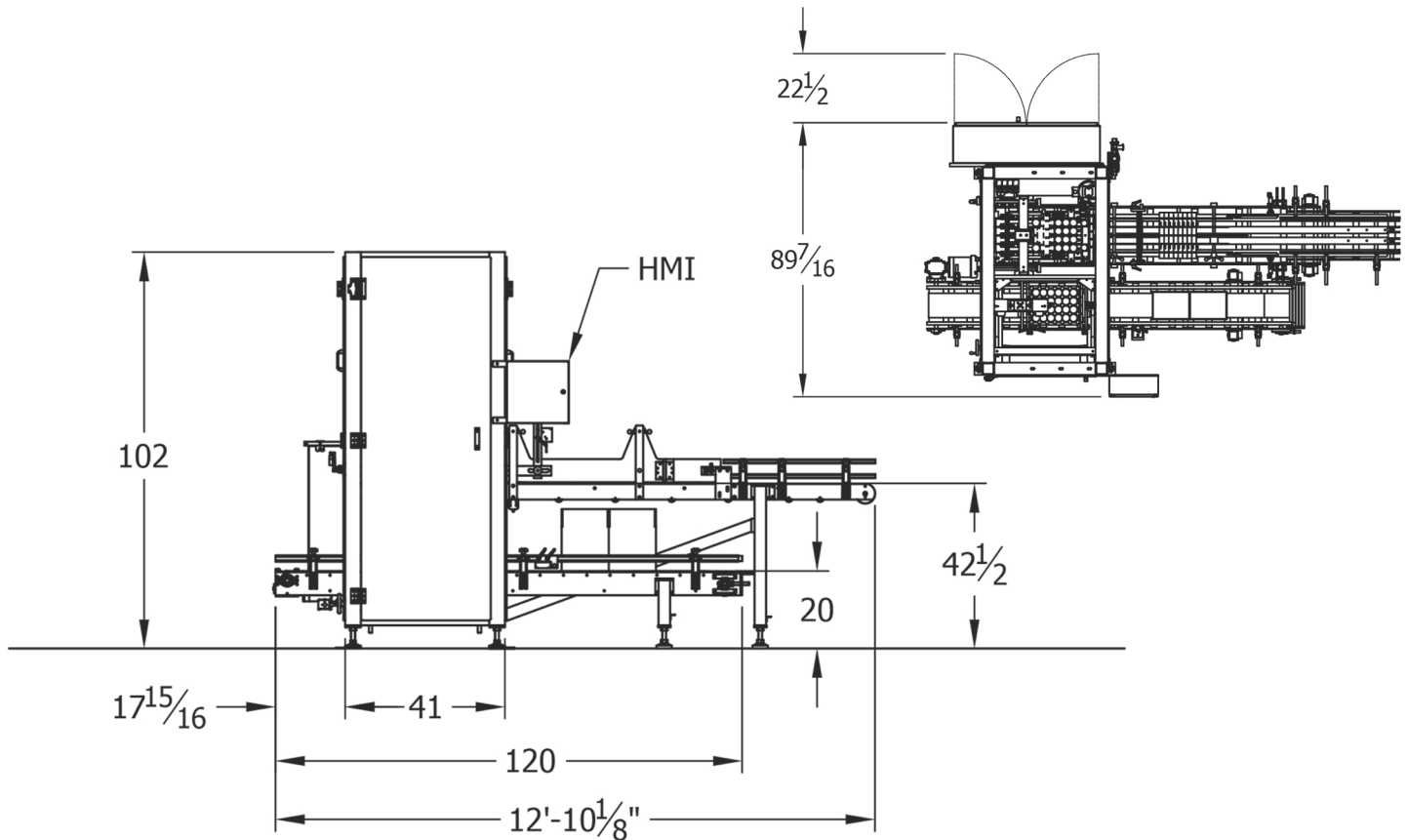

Unit Specifications:

Gently pack fragile product using a servo controlled two-axis overhead pick & place

Tooling featuring gripper, vacuum, or bladder assemblies

Change out tooling and basket assembly in minutes

Single case infeed with cycle times up to 15 per minute.

*speeds may increase depending on application

Upgrades Available:

"D" Series for non-round containers

Four flap opener for reshipper cases

Down bottle detection

No-tool quick changover

4-Tier flashing light tree for interrupted cycles

Upgrade to CP20 for higher speeds

One (1) Year Warranty and 100% Money Back Guarantee Always Included